

# Solid State Relays

## SOLITRON MIDI Multi-Function Analog Switching

### Type RJ1P

CARLO GAVAZZI



- AC semiconductor contactor
- Multi-function - 5 selectable modes of operation: Phase Angle, Distributed Full Cycle and Burst Control (1, 3 and 10s)
- Direct copper bonding (DCB) technology
- LED-indication for control and load status
- Operational ratings up to 50 AACrms and 600 VAC
- 4-20mA or 0-10V control input
- Built-in varistor
- Non-repetitive voltage: Up to 1200Vp
- Opto-isolation > 4000VACrms
- Cage clamp terminals
- IP20 protection

## Product Description

The Solitron Midi Analog Switching is a single-phase SSR that provides proportional output power in relation to the control signal level applied. This microprocessor-based device provides for 5 different switching modes integrated into one package. A selector switch on the front of the device is used for the selection of the preferred mode of operation, i.e., either Phase Angle, Distributed Full Cycle or Burst

Control. This multi-function selection makes this device ideal for the control of a variety of loads, including heaters and lamps. The control signal can be either 4 - 20mA or 0 - 10VDC. 4mA or 0V correspond to zero output power, whilst 20mA or 10VDC correspond to full output power.

The product is ready to mount on DIN-rail or chassis and comes with integral heatsink.

## Ordering Key

**RJ 1 P 48 V 50 E**

Solid State Relay \_\_\_\_\_  
 Number of poles \_\_\_\_\_  
 Switching mode (Proportional) \_\_\_\_\_  
 Rated operational voltage \_\_\_\_\_  
 Control input type \_\_\_\_\_  
 Rated operational current \_\_\_\_\_  
 Terminal layout \_\_\_\_\_

## Type Selection

Switching mode	Rated operational voltage	Control input	Rated operational current	Terminal layout
P: Proportional Output	23: 230VACrms 48: 480VACrms 60: 600VACrms	V: 0 - 10VDC I: 4 - 20mA	50: 50AACrms	E: Contactor

## Selection Guide

Rated operational voltage	Non-rep. voltage	Control input	Supply voltage	Rated operational current (50 A)
230VACrms	650Vp	0 - 10VDC 4 - 20mA	24VAC/DC	<b>RJ1P23V50E</b> <b>RJ1P23I50E</b>
480VACrms	1200Vp	0 - 10VDC 4 - 20mA	24VAC/DC	<b>RJ1P48V50E</b> <b>RJ1P48I50E</b>
600VACrms	1200Vp	0 - 10VDC 4 - 20mA	24VAC/DC	<b>RJ1P60V50E</b> <b>RJ1P60I50E</b>

## Insulation

Rated insulation voltage	≥ 4000 VACrms
Input to output	
Output to case	

## Thermal Specifications

Operating temperature	-20 to +60°C (-4 to +140 °F)
Storage temperature	-40 to +100°C (-40 to +212 °F)

## General Specifications

	RJ1P23...	RJ1P48...	RJ1P60...
Operational voltage range	90 to 265VAC	200 to 550VAC	410 to 660VAC
Non-rep. peak voltage	650V <sub>p</sub>	1200V <sub>p</sub>	1200V <sub>p</sub>
Operational frequency range	45 to 65Hz	45 to 65Hz	45 to 65Hz
Output power	0 to 99%	0 to 99%	0 to 99%
Power factor	≥ 0.9 @ 230VACrms	≥ 0.9 @ 480VACrms	≥ 0.9 @ 600VACrms
Load status indication	Red LED	Red LED	Red LED
Output power resolution			
MODE 1   Phase Angle	1/300 @ 50Hz, 1/300 @ 60Hz		
MODE 2   Full Cycle	1/64 @ 50Hz, 1/64 @ 60Hz		
MODE 3   Burst with 1s period	1/50 @ 50Hz, 1/60 @ 60Hz		
MODE 4   Burst with 3s period	1/150 @ 50Hz, 1/180 @ 60Hz		
MODE 5   Burst with 10s period	1/500 @ 50Hz, 1/600 @ 60Hz		
Approvals	UL, cUL		
CE-marking	Yes		

## Input Specifications

	RJ1P..I...		RJ1P..V...
<b>Current controlled input</b>		<b>Voltage controlled input</b>	
Control current range	4 - 20mA	Supply voltage range, V <sub>ss</sub>	20 - 28VAC/DC
Max. allowable input current	50mA	Supply current	18mA @ 24VDC 23mA @ 24VAC
Pick up current	4.2mA	Control voltage range, V <sub>cc</sub>	0 - 10VDC
Drop out current	3.9mA	Control input current	0.1mA @ 10VDC
Control status indication	Green LED	Reverse polarity protected	Yes
Reverse polarity protected	Yes	Pick up voltage	0.5VDC
Voltage drop	10VDC @ 20mA	Drop out voltage	0.05VDC
		Control status indication	Green LED

## Housing Specifications

Weight	Approx. 430 g
Housing material	PBT Flame retardant
Control terminal cable size	
Min	1 x 0.5 mm <sup>2</sup> (1 x AWG20)
Max	1 x 4.0 mm <sup>2</sup> (1 x AWG12) or 2 x 2.5 mm <sup>2</sup> (2 x AWG14)
Mounting torque max.	0.6 Nm Posidriv 0 bit
Control terminal screw	M3
Power terminal cable size	
Min	1 x 4 mm <sup>2</sup> (1 x AWG12)
Max	1 x 25 mm <sup>2</sup> (1 x AWG3) or 2 x 10 mm <sup>2</sup> (2 x AWG6)
Mounting torque max.	2.5 Nm Posidriv 2 bit
Power terminal screw	M5

## Output Specifications

Rated operational current AC51 @Ta=25°C	50AACrms
Min. operational current	150mAACrms
Rep. overload current t=1 s (T <sub>j</sub> init.=25°C)	< 200AACrms
Non-rep. surge current t=10 ms (T <sub>j</sub> init.=25°C)	1900A <sub>p</sub>
Off-state leakage current, @ rated voltage and frequency	< 3 mArms
I <sup>2</sup> t for fusing t=10 ms	18000A <sup>2</sup> s
On-state voltage drop @ rated current	1.6Vrms
Critical dV/dt off-state	1000V/μs

## Terminal Layout

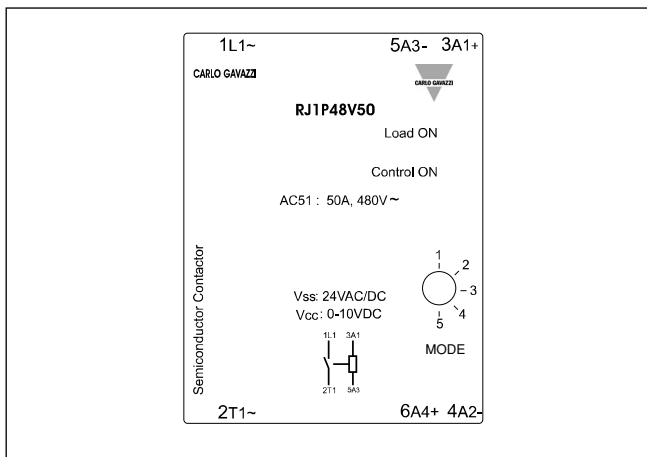

## Mode Selection

- MODE 1 Phase Angle Switching
- MODE 2 Distributed Control
- MODE 3 Burst Switching (1 sec. period)
- MODE 4 Burst Switching (3 sec. period)
- MODE 5 Burst Switching (10 sec. period)

## Transfer characteristics

Output power as a function of control input

Control Current (mA)	Control Voltage (VDC)	Output Power (%)
4	0	0
8	2.5	25
12	5	50
16	7.5	75
20	10	99

## Connection Examples

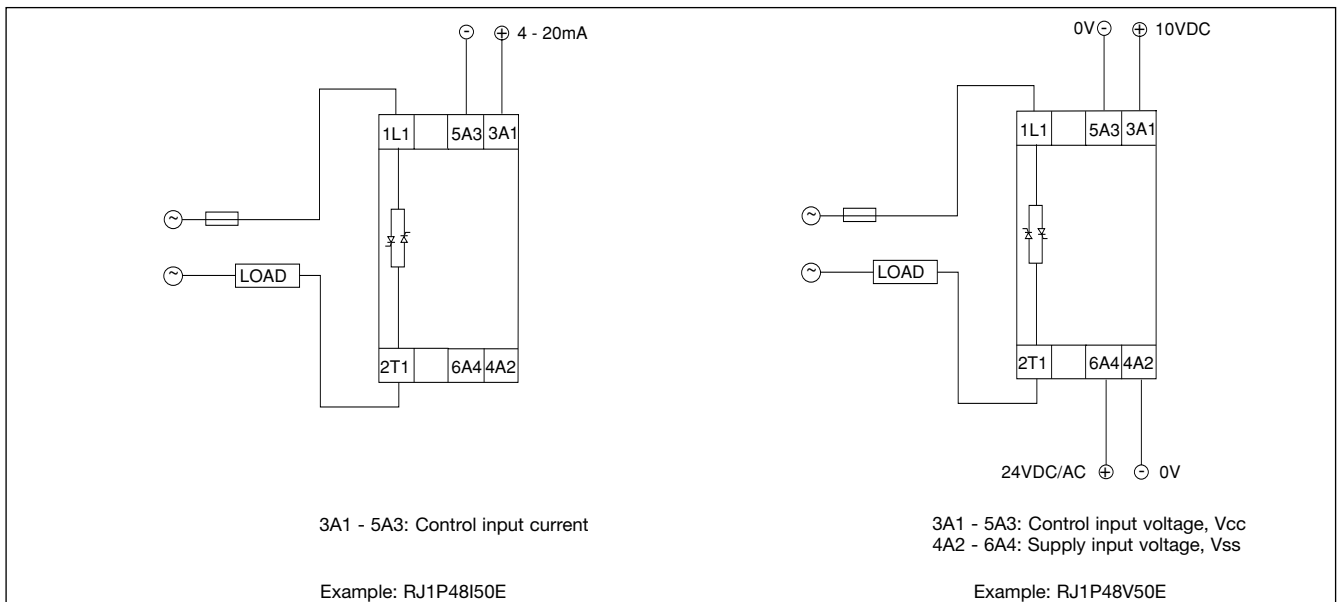

Note: For the RJ1P.V..., it is possible to have the ground terminals of the supply and control power supplies used commoned. In the case, this common ground is connected either to terminal A2 or terminal A3. This is only applicable when a 24 VDC supply voltage is used. There should be no external direct link from terminal A2 to Terminal A3.

## Operation

**MODE 1:** The Phase Angle switching mode works in accordance with the phase angle control principle, i.e. the output switching point in the AC sine wave depends on the signal level applied at the input. The relay switches off everytime the output current crosses zero.

**MODE 2:** The Distributed mode provides a number of full cycles, evenly distributed over a fixed period of 1.28s @ 50Hz (1.07s @ 60Hz), depending on the control input.

**MODE 3, 4, 5:** The Burst Switching mode generates a number of full cycles, depending on the control input over fixed periods of 1s, 3s or 10s for MODES 3, 4 and 5 respectively.

**Modes 2, 3, 4 and 5** use the zero switching principle, thus ensuring a reduced level of radiated and wire-conducted noise. The Distributed and Burst Switching modes are not recommended for light control due to light-flickering.

### LED INDICATION

The top Red LED indicates the load status. It goes ON whenever the load is activated. The Green LED gives indication of the status of the control input.

Upon application of control current (for the RJ1P.l...) to terminals A1-A3, the Green LED will be dimly lit, with its intensity increasing with an increase in control current.

For the RJ1P.V..., the Green

LED will be ON (flickering) upon application of the supply voltage to terminals A2 - A4. Once a control voltage is applied to terminals A1 - A3, the Green LED will be fully ON, if greater than a threshold voltage (approx. 0.5V). Note that the first time the device (voltage control version) is to be activated, the mains voltage has to be present for the Green LED to indicate the control status.

## Functional Diagram

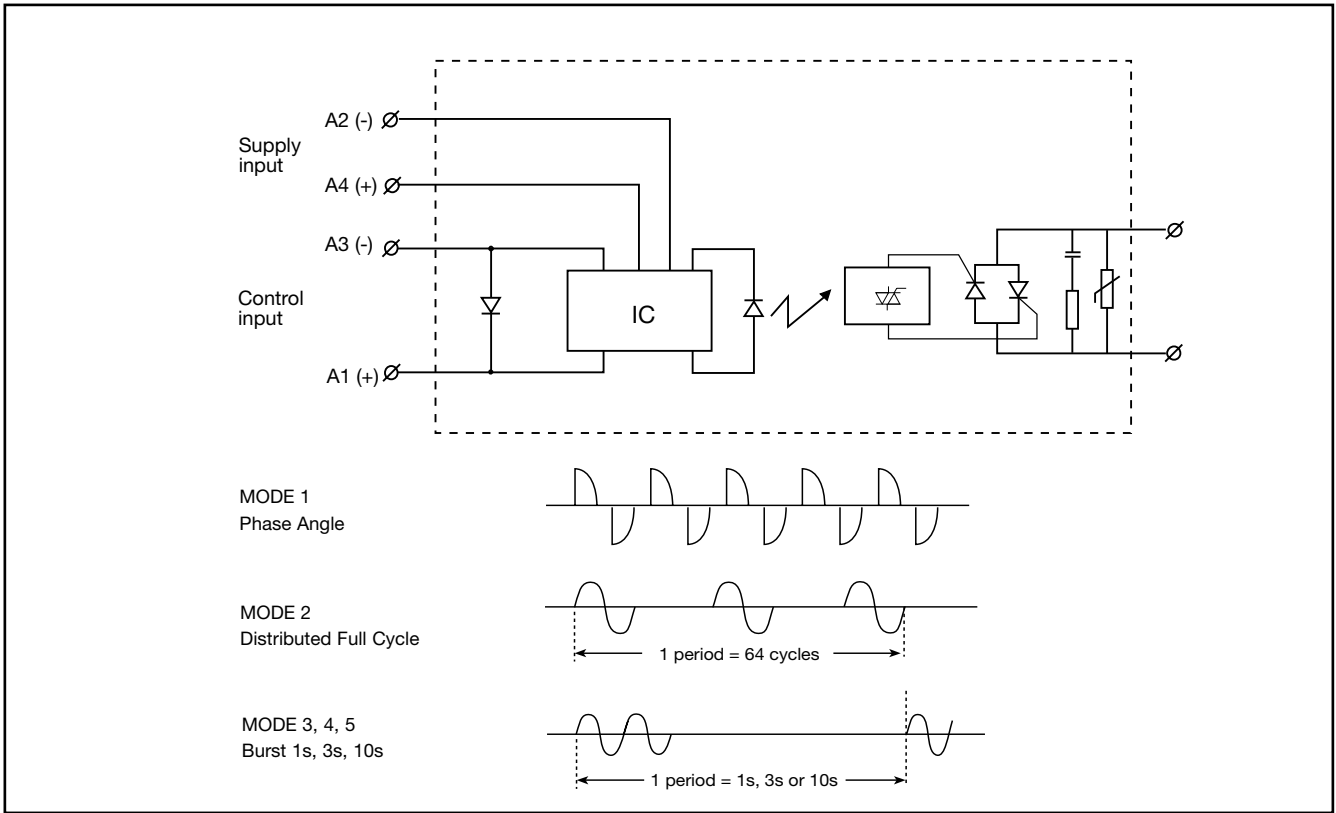

Note: A2, A4 used only for voltage control version

## Derating Curve

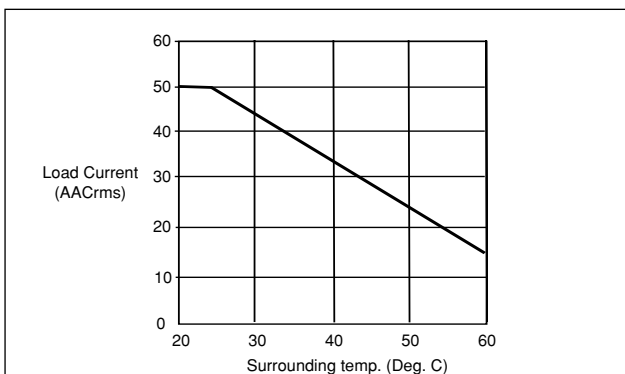

Note: Based on 100% output power

## Dissipation Curve

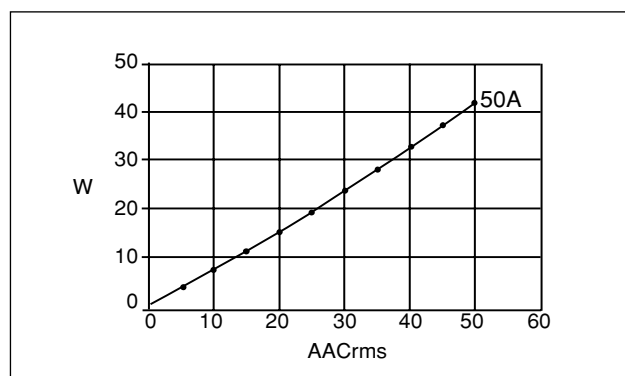

## Dimensions

